

AM100-PRO

Vehicle Signal Booster Kit

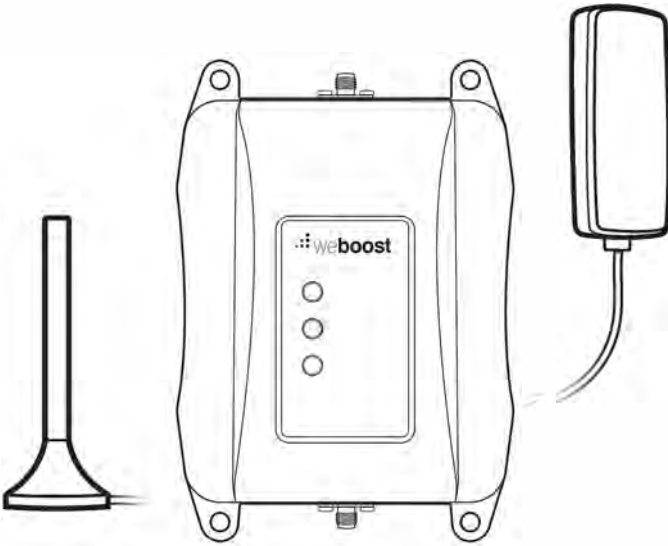

User Manual

Index

Package Contents 1

STEP 1: Mount Outside Magnetic Antenna 2

STEP 2: Mount Inside Antenna 4

STEP 3: Connect Coax Cables To Booster 5

STEP 4: Connect Power Supply To Booster 6

STEP 5: Plug Power Adapter Into Vehicle’s Power Supply ... 7

Light Patterns 8

Troubleshooting 9

Safety Guidelines 10

Specifications 11

Warranty 12

Package Contents

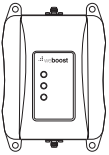

AM100-Pro
Booster



Outside
Antenna



Inside
Antenna



Power
Supply

Step 1: Mount Outside Magnetic Antenna



Identify a location on the top of your vehicle that is:

- Near the center of the roof
- At least 30 centimeters away from any other antennas
- At least 30 centimeters away from any windows (including sunroofs)



Clean the surface where you will place the outside antenna.



Mount the outside antenna by placing on top of vehicle.

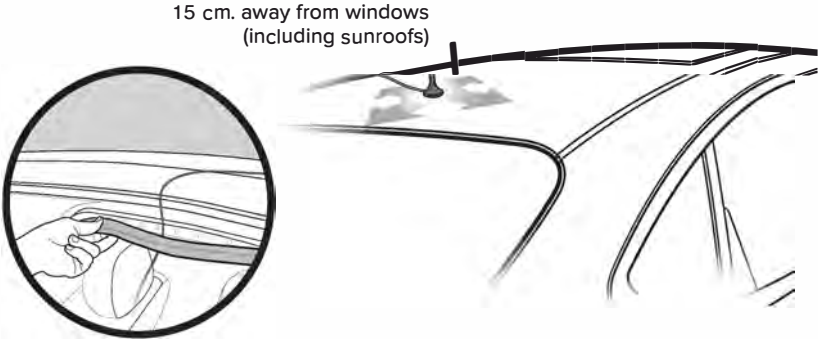

NOTE: For roofs that are non-magnetic, call Tech Support **011 749 3085** for an adhesive disk to mount the outside antenna.



WORKS WITH ALL VEHICLES

(STEP 1 cont.)

Different vehicles cable can be routed. See examples below.

NOTE: The cable is strong enough that it may be shut in most vehicle doors without damaging the cable.



Car/Sedan: Cable routed into rear side door.

NOTE: When going through car wash, remember to remove your antenna.

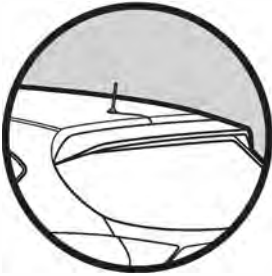

SUV/Van/Hatchback: Cable routed into top of hatchback door.

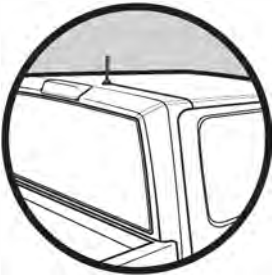

Truck: Cable routed into side door.

Step 2: Mount Inside Antenna

Identify a place to mount the 4G In-Vehicle Antenna, either on the side of the seat or on the dash and mount. The location should be at least 45 centimeters but no more than 90 centimeters from where the cellular device will be used. Use the Velcro® adhesive strip/adhesive strip provided and attach to desired location.

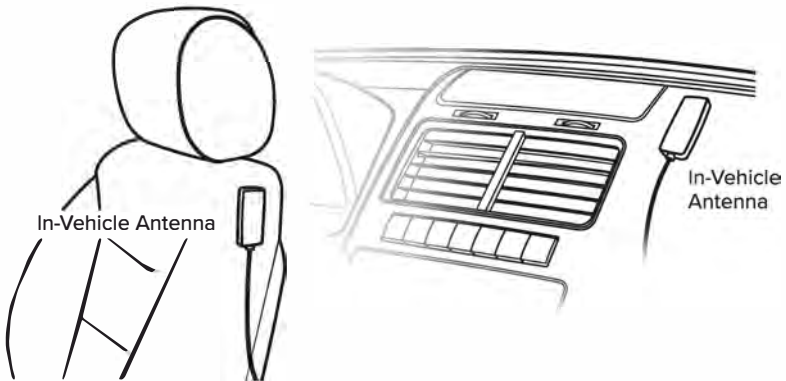

Step 3: Connect Coax Cables To Booster

Connect the cable from the Mini-Mag Mount Antenna to the port labeled “Outside Antenna” on the Drive AM100-Pro booster.

NOTE: Bracket can be used to fasten booster in a specific location if desired.

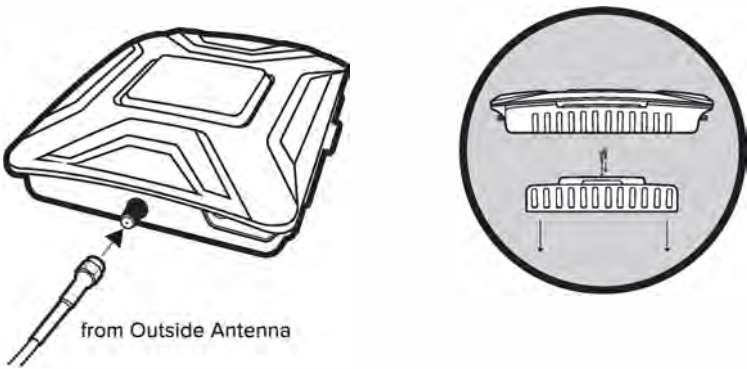

Connect the cable from the 4G In-Vehicle Antenna to the port labeled “Inside Antenna” on the booster.

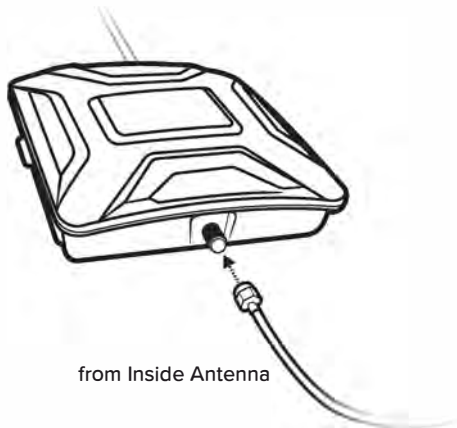

Step 4: Connect Power Supply To Booster

Connect the power supply cord to the end of the AM100-Pro labeled "Power."

NOTE: Do NOT connect the power to the Signal Booster until you have connected both the Inside and Outside Antennas.

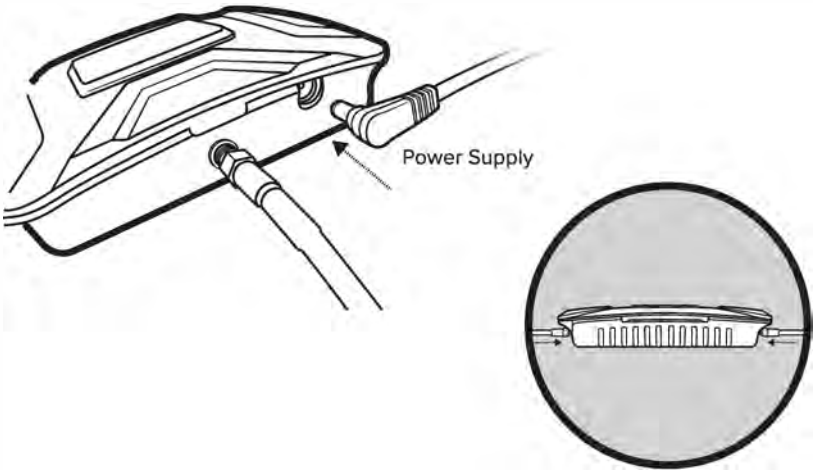

Step 5: Plug Power Adapter Into Vehicle's Power Supply

Plug the power adapter into vehicle's 12V DC power supply. Power up your AM100-Pro by flipping the switch on the back of the DC power adapter on. If your Drive AM100-Pro is working correctly, the light will be green.

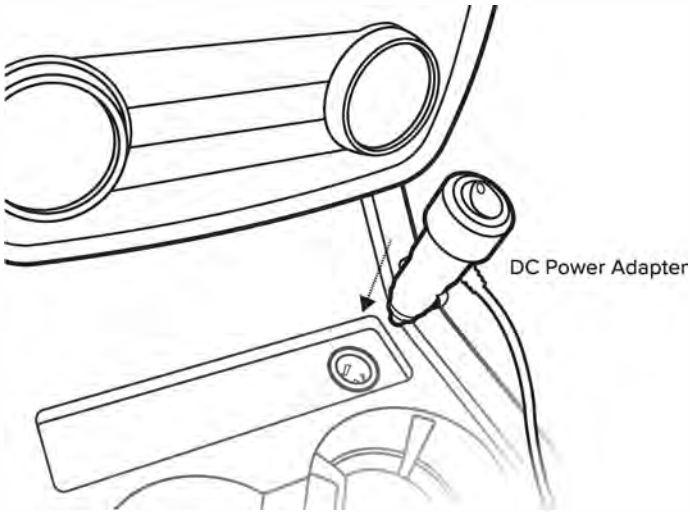

NEED HELP?

 boltontechnical.co.cza

 011 749 3085

Light Patterns

Solid Green

This indicates that your booster is functioning properly and there are no issues with installation.

Blinking Red, Then Solid Green

This indicates that one or more of the booster bands has reduced power due to a feedback loop condition called oscillation. This is a built in safety feature to prevent harmful interference with a nearby cell tower. If you are already experiencing the desired signal boost, then no further adjustments are necessary. If you are not experiencing the desired boost in coverage then refer to the Troubleshooting section below.

Solid Red

This is due to a feedback loop condition called oscillation. This is a built in safety feature that causes a band to shut off to prevent harmful interference with a nearby cell tower. Refer to Troubleshooting section below.

Light Off

If the AM100-Pro Signal Booster's light is off, verify your power supply has power.

NOTE: The Signal Booster can be reset by disconnecting and reconnecting the power supply.

After troubleshooting you must initiate a new power cycle by disconnecting and then reconnecting power to the Booster.

NEED HELP?



boltontechnical.co.cza



011 749 3085

Troubleshooting

FIXING BLINKING OR SOLID RED ISSUES

This section is only applicable if the booster is red or blinking red and you are not experiencing the desired signal boost.

- 1 Unplug the Booster's power supply.
- 2 Relocate the inside and outside antenna further from each other. The objective is to increase the separation distance between them, so that they will not create this feedback condition discussed before.
- 3 Plug power supply back in.
- 4 Monitor the indicator light on your booster. If, after a few seconds of 'power on', a solid or blinking red light appears, repeat steps 1 through 3. Increase the separation distance until the condition is corrected and/or desired coverage area is achieved. Note: Horizontal separation of the two antennas typically requires a shorter separation distance than perpendicular separation.
- 5 If you are having any difficulties while testing or installing your booster, contact our weBoost Customer Support team for assistance (011 749 3085).

FREQUENTLY ASKED QUESTIONS

What hours can I contact customer support?

Customer Support can be reached Monday to Friday by calling 011 749 3085 or through our support site at www.boltontechical.co.za

Why do I need to create distance between the booster and the antenna?

Antennas connected to a booster create spheres of signal. When these spheres overlap, a condition called oscillation occurs. Oscillation can be thought of as noise, which causes the booster to shut down to prevent damage. The best way to keep these spheres of signal from overlapping is to maximize separation between the Booster and Antenna.

Safety Guidelines

Use only the power supply provided in this package. Use of a non-weBoost product may damage your equipment.

Any antenna used with this device must be located at least 20 centimeters from all persons.

This is a CONSUMER device.

The AM100-Pro is an ICASA Approved and Registered Device. Most wireless providers consent to the use of signal boosters. Some providers may not consent to the use of this device on their network. If you are unsure, contact your provider.

You **MUST** cease operating this device immediately if requested by ICASA or licensed wireless service provider.

Specifications

AM100-Pro Specifications

Product	weBoost Signal Booster		
Model Number	AM100-pro		
Connectors	SMA		
Antenna Impedance Ohm	50		
Frequency MHz	1920-1980 / 2110-2170	1710-1785 / 1805-1880	880-915 / 925-960
Bands	B1	B3	B8
Passband Gain UL/DL	53.9 / 53.7	49.8 / 51.8	49.3 / 50.1
20 dB Bandwidth (MHz)			
	Typical		
	Maximum		
	74.8	85.6	39.4
	77.4	86.7	41.5
Power output for single cell phone (dBm)			
	Uplink	20.2	21.2
	Downlink	2.8	3.2
Power output for multiple received channels (Uplink) dBm			
	No. Tones		
	2	20.2	21.2
	3	18.4	19.4
	4	17.2	18.2
	5	16.2	17.2
	6	15.4	16.4
Power output for multiple received channels (Downlink) dBm			
	No. Tones		
	2	2.8	3.2
	3	1	1.4
	4	-0.2	0.2
	5	-1.2	-0.8
	6	-2	-1.6
Noise Figure UL/DL	7.4 / 7.0	5.0 / 6.0	4.4 / 4.4
Isolation dB	-65		
Power Requirements	6 V, 1.5A		

The Manufacturer's rated output power of this equipment is for single carrier operation. For situations when multiple carrier signals are present, the rating would have to be reduced by 3.5 dB, especially where the output signal is re-radiated and can cause interference to adjacent band users. This power reduction is to be by means of input power or gain reduction and not by an attenuator at the output of the device.



1 YEAR WARRANTY

weBoost Signal Boosters are warranted for one (1) years against defects in workmanship and/or materials. Warranty cases may be resolved by returning the product directly to the reseller with a dated proof of purchase.

Signal Boosters may also be returned directly to the manufacturer at the consumer's expense, with a dated proof of purchase and a Returned Material Authorization (RMA) number supplied by weBoost. weBoost shall, at its option, either repair or replace the product.

This warranty does not apply to any Signal Boosters determined by weBoost to have been subjected to misuse, abuse, neglect, or mishandling that alters or damages physical or electronic properties.

Replacement products may include refurbished weBoost products that have been recertified to conform with product specifications.

RMA numbers may be obtained by contacting Customer Support

DISCLAIMER: The information provided by weBoost is believed to be complete and accurate. However, no responsibility is assumed by weBoost for any business or personal losses arising from its use, or for any infringements of patents or other rights of third parties that may result from its use.

NEED HELP?



boltontechnical.co.cza



011 749 3085



Represented by Bolton Technical: Sole Distributors in South Africa

 011 749 3085  boltontechnical.co.za

Copyright © 2017 weBoost. All rights reserved.

weBoost products covered by U.S. patent(s) and pending application(s)

For patents go to: weboost.com/us/patents

Approved for use in South Africa by ICASA.